

For use in 0.745" to 0.775" diameter dog holes at least 1 1/4" deep.

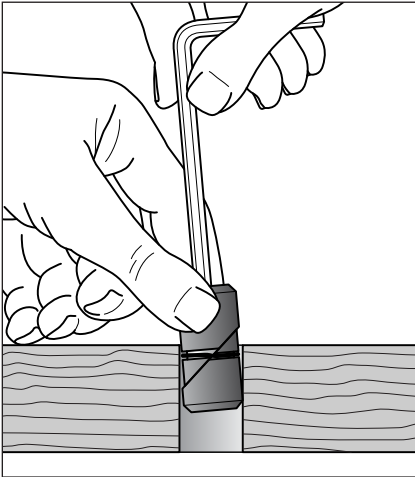

Figure 1: Place bench anchor in dog hole and adjust O-ring friction with a 3/16" hex key.

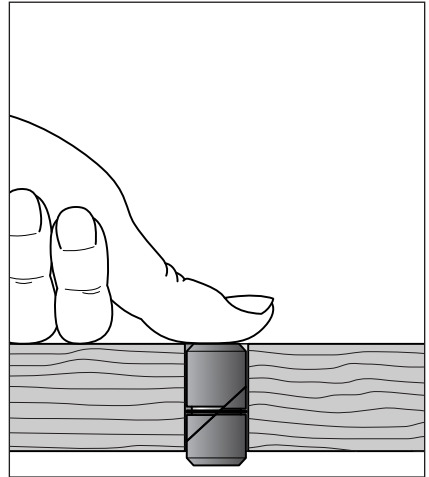

Figure 2: Push anchor down to desired depth.

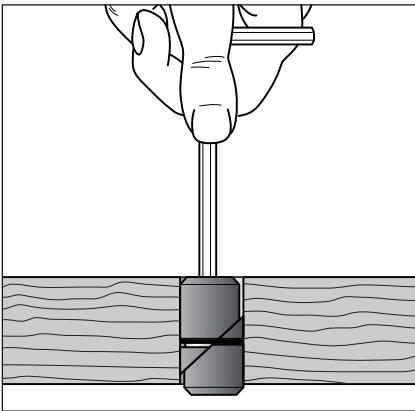

Figure 3: Tighten screw to lock anchor.

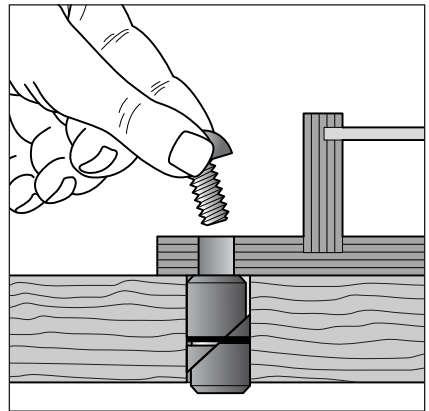

Figure 4: Attach jig or fixture with 1/2-13 fasteners.